

F8L10-N LoRa Module User Manual	Document Version	Page
	V2.0.0	
	Product Name: F8L10-N	Total:16

# F8L10-N LoRa Module User Manual

The user manual is suitable for the following model:

Model	Product Type
F8L10-N-433	SPI LoRa Module: 433/470MHz
F8L10-N-868	SPI LoRa Module: 868/915MHz



[Xiamen Four-Faith Communication Technology Co., Ltd.](#)

Add: Floor 11, Area A06, No 370, chengyi street, Jimei, Xiamen

Tel: +86 592-5907276 Fax:+86 592-5912735

Web:en.four-faith.com



## Files Revised Record

Date	Version	Remark	Author
2017-05-02	V1.0.0	Initial version	XQQ
2017-10-10	V2.0.0	Change of company address	LXP

## Copyright Notice

All contents in the files are protected by copyright law, and all copyrights are reserved by Xiamen Four-Faith Communication Technology Co., Ltd. Without written permission, all commercial use of the files from Four-Faith are forbidden, such as copy, distribute, reproduce the files, etc., but non-commercial purpose, downloaded or printed by individual (all files shall be not revised, and the copyright and other proprietorship notice shall be reserved) are welcome.

## Trademark Notice

Four-Faith、四信、、、 are all registered trademarks of Xiamen Four-Faith Communication Technology Co., Ltd., illegal use of the name of Four-Faith, trademarks and other marks of Four-Faith is forbidden, unless written permission is authorized in advance.

# Contents

Chapter 1 Brief Introduction of Product.....	5
1.1 General.....	5
1.2 Features and Benefits.....	5
1.3 Specifications.....	6
Chapter 2 Module Interface.....	8
2.1 Module Signal Definition.....	8
2.2 SPI interface.....	9
2.3 Digital IO pin mapping.....	9
2.4 TXEN, RXEN control (optional).....	10
2.5 RESET.....	10
Chapter 3 Hardware Application.....	11
3.1 Hardware Connection.....	11
3.2 Hardware Design.....	11
3.3 Outline Dimension.....	12
3.5 Tape and packaging instructions.....	13
3.6 Re-flow Temperature Specification.....	14
Chapter 4 Ordering Information.....	16

## Chapter 1 Brief Introduction of Product

### 1.1 General

F8L10-N module is mainly used LoRa™ long range modem for ultra-long distance spread spectrum communication, and high interference immunity whilst minimising current consumption.

Using F8L10-N module based on LoRa™ spread spectrum modulation technology, can achieve a sensitivity of over -148dbm. The high sensitivity combined with the integrated +20 dBm power amplifier yields industry leading link budget making it optimal for any application requiring range or robustness. LoRa™ also provides significant advantages in both blocking and selectivity over conventional modulation techniques, solving the traditional design compromise between range, interference immunity and energy consumption.

The module is suitable for any environment of complex wireless data transmission applications, such as: wireless meter reading, power line online monitoring, intelligent parking, soil temperature and humidity monitoring, intelligent irrigation, photovoltaic array monitoring applications.

### 1.2 Features and Benefits

#### Design for Industrial Application

- ◆ Based on LoRa™ Spread Spectrum Modulation.
- ◆ Support a variety of frequency bands around the world:433/470/868/915 MHz
- ◆ 2.4-3.6V wide voltage range.
- ◆ +20 dBm (100 mW) constant RF output.
- ◆ High sensitivity: down to -148 dBm.
- ◆ Low current of 200 nA register retention.
- ◆ Automatic RF signal detection, CAD detection, sleep and other modes of arbitrary switch.
- ◆ Nested shield cover protection, increase anti-jamming performance.

#### Stability and Reliability

- ◆ Micro-dual 2.00mm \* 8-pin package is also compatible with half-hole, you can use the user's own needs flexible
- ◆ Half-duplex communication, standard SPI communication control.
- ◆ Easy to use, flexible, a variety of work mode selection

### Application

- ◆ Power line on-line monitoring
- ◆ Smart parking
- ◆ Soil temperature and humidity monitoring
- ◆ Intelligent irrigation
- ◆ Wireless remote meter reading
- ◆ PV array monitoring

## 1.3 Specifications

### LoRa Specification

Item	Content
Communication Protocol and Band	Support a variety of frequency bands around the world:433/470/868/915 MHz
Indoor/Urban Range	1km
Outdoor/RF Line-of-Sight Range	3.5km
Transmit Power	20dBm(100mW)
Receiver Sensitivity	-140dBm

### Interface Type

Item	Content
SPI	Standard 4-wire SPI interface
Antenna connector	Antenna Pad
Package	2.00mm * 8 double row pin is compatible with SMT half hole

### Power supply

Item	Content
Recommended Power	3.3V
Power Range	2.4-3.6V

### Power Consumption

	Item	Content
F8L10-N	RX Mode	<12mA@3.3VDC
	TX Mode	108-115mA@3.3VDC(Maximum pulse current≤130mA )
	Deep Sleep	<1.0uA@3.3VDC

### Physical Characteristics

	Item	Content
F8L10-N	Dimensions	16.0x16.0x3.0 mm (Without antenna and connector)
	Weight	3.0g

### Environmental Limits

Item	Content
Operating Temperature	-40~+85°C(-40~+185°F)
Storage Temperature	-40~+125°C (-40~+257°F)
Operating Humidity	95%(unfreezing)

## Chapter 2 Module Interface

### 2.1 Module Signal Definition

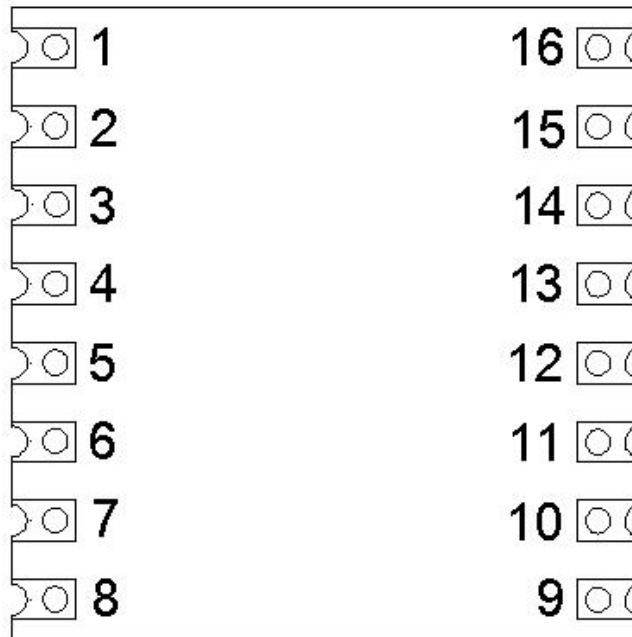

Figure 2-1 Module Pin Diagram F8L10-N

Table 2-1-1 Module interface definition

Number	Name	Type	Description
1	GND	-	Ground
2	MISO	SPI	SPI Data Output
3	MOSI	SPI	SPI Data Input
4	SCK	SPI	SPI Clock Input
5	NSS	SPI	SPI Chip select Input
6	RESET	I/O	Reset trigger Input
7	DIO5	I/O	Digital I/O
8	GND	-	Ground
9	ANT	-	RF Signal Input/output
10	GND	-	Ground
11	DIO3	I/O	Digital I/O
12	DIO4/RXEN	I/O	Digital I/O,RX ENABLE(optional)
13	VDD	-	Supply voltage
14	DIO2/TXEN	I/O	Digital I/O,TX ENABLE(optional)



15	DIO1	I/O	Digital I/O
16	DIO0	I/O	Digital I/O

**Note:** The signal Input/Output relative to the module.

## 2.2 SPI interface

F8L10-N wireless spread spectrum module is a standard 4-wire SPI interface, the customer can use the MCU IO port simulation, you can also use the MCU comes with the SPI interface to communicate. If you use IO port simulation, pay attention to the high-speed MCU above the delay. The module SPI provides three read and write modes.

1: an address followed by a data, NSS from the write address to (write / read) data are low. Until the data is completed.

2: an address followed by N data, after the data write address also followed by the increase, until the corresponding data. NSS from address operation to data completion are low.

3: FIFO address operation, write FIFO address, the data written or read after the address does not increase, but stored in the FIFO address or output.

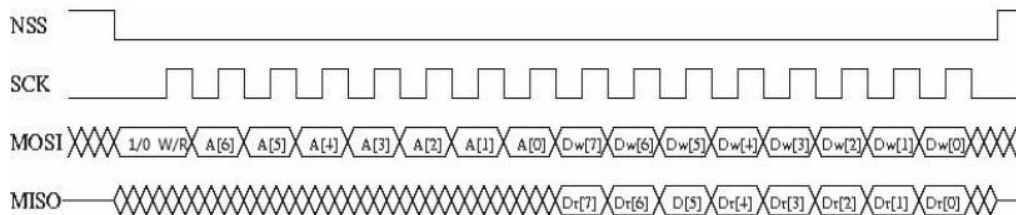

Figure 2-1 SPI Timing Diagram

## 2.3 Digital IO pin mapping

The F8L10-N module has six general purpose IO pins that are available in LoRa™ mode. Their mapping depends on the RegDioMapping1 and RegDioMapping2 configuration of the two registers, see the table below.

**Table 2-2 DIO Mapping in LoRa™ mode**

Operatin g mode	DIOx Mappi ng	DIO5	DIO4	DIO3	DIO2	DIO1	DIO0
ALL	00	ModeRea dy	CadDetect ed	CadDone	FhssChange Channel	RxTimeout	RxDone
	01	ClkOut	PIILock	ValidHead er	FhssChange Channel	FhssChangeC hannel	TxDone
	10	ClkOut	PIILock	PayloadCr cError	FhssChange Channel	CadDetected	CadDone

	11	-	-	-	-	-	-
--	----	---	---	---	---	---	---

## 2.4 TXEN, RXEN control (optional)

TXEN, RXEN pin, mainly used to switch the RF switch, in the transmitter mode and receive mode switch RF switch, the user can connect through the CPU IO transceiver switch. The hardware principle of the F8L10-N module is controlled in the transmit and receive modes as shown in Table 2-3 below.

**Table 2-3 Opration of TXEN/RXEN**

TX MODE	TXEN	RXEN	RX MODE	TXEN	RXEN
	High level	Low level		Low level	High level

Note: The default use of the module to switch.

## 2.5 RESET

RESET pin is mainly to reset the F8L10-N module, active low (at least save 100us), high level operation. Note that this pin is generally in the initialization time to operate, the initialization operation is strictly prohibited after the use of this pin, to keep the RESET pin high.

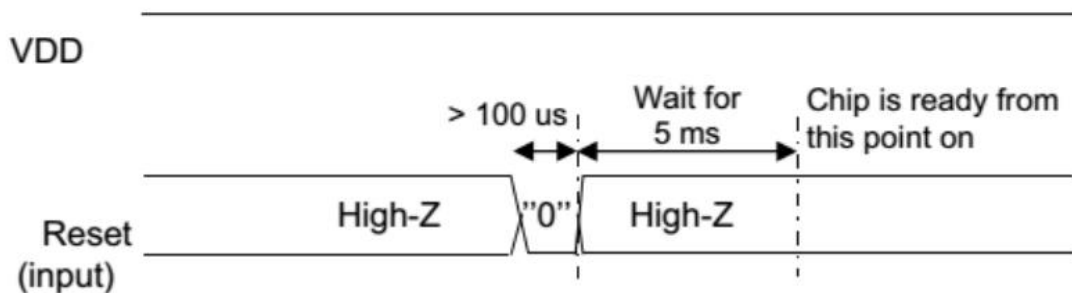

## Chapter 3 Hardware Application

### 3.1 Hardware Connection

1. The F8L10-N is connected to the client MCU hardware, as shown in Figure 3-1:

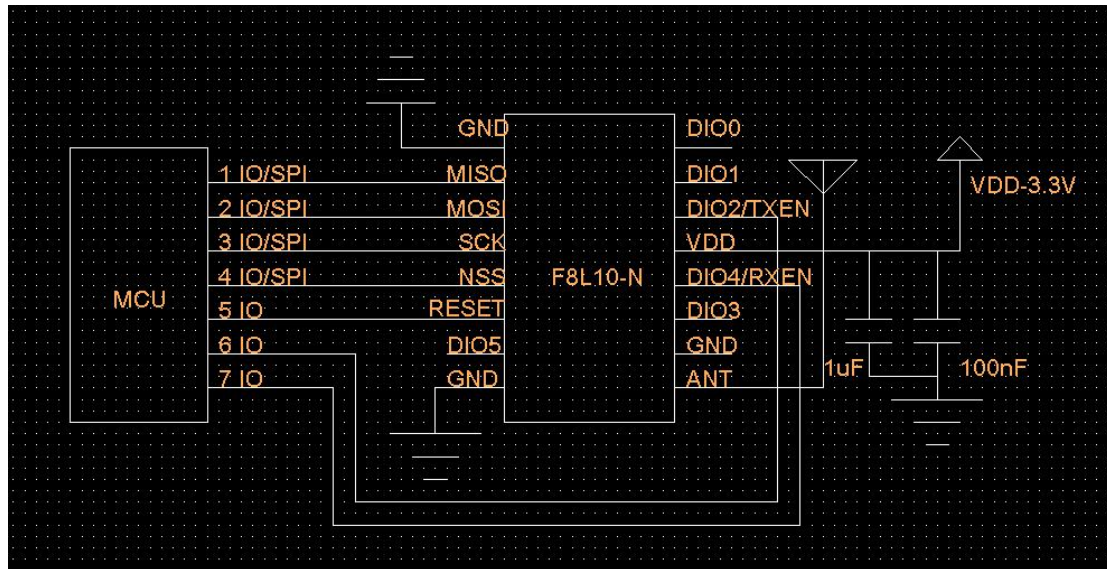

Figure 3-1 F8L10-N and client MCU hardware connection diagram

### 3.2 Hardware Design

The F8L10-N module is compatible with plug-in and plug-in radio frequency modules, so customers should design the board as a component unit when designing the board. So in the PCB layout and alignment should pay attention to the following two points.

#### 1, PCB layout

In the PCB layout, in line with the premise of the mold structure, the wireless module should be away from the power devices, magnetic devices, such as: speakers, buzzers, switching power supply inductance and other devices can produce magnetic interference and heating devices. In the paste module area, the PCB is prohibited on the back of the device. If the built-in spring antenna, then the antenna can not be placed and the module placed overlapping, either vertical PCB board, or parallel module board edge.

If the antenna is soldered on the customer's PCB board, the antenna's solder joints are as close as possible to the module, and the RF traces are as short as possible. In the power interface as much as possible to put a quick response to the capacitor device to protect the power instantaneous pulse.

#### 2, PCB alignment

The connection of the data lines is best parallel, on the same side, the line as long

as possible. Paste the area within the module should avoid alignment, try to keep the integrity of copper. But the antenna below the ban on the shop with copper, it is best to emptied circuit board.

### 3.3 Outline Dimension

With shielding cover thickness of about 3.0mm, excluding connectors

The size of the F8L10-N module is shown below:

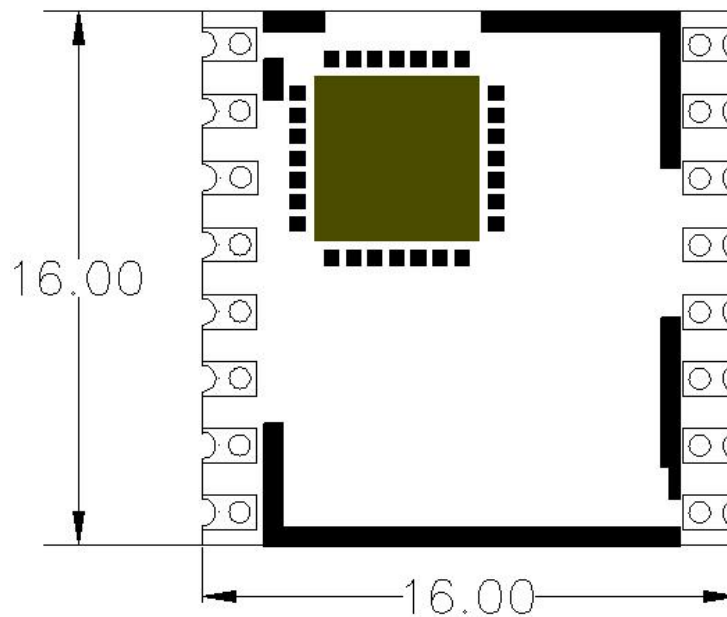

Figure 3-2 F8L10-N Outline Dimension

### 3.4 PCB Footprint

F8L10-N Outline Package, unit: mm

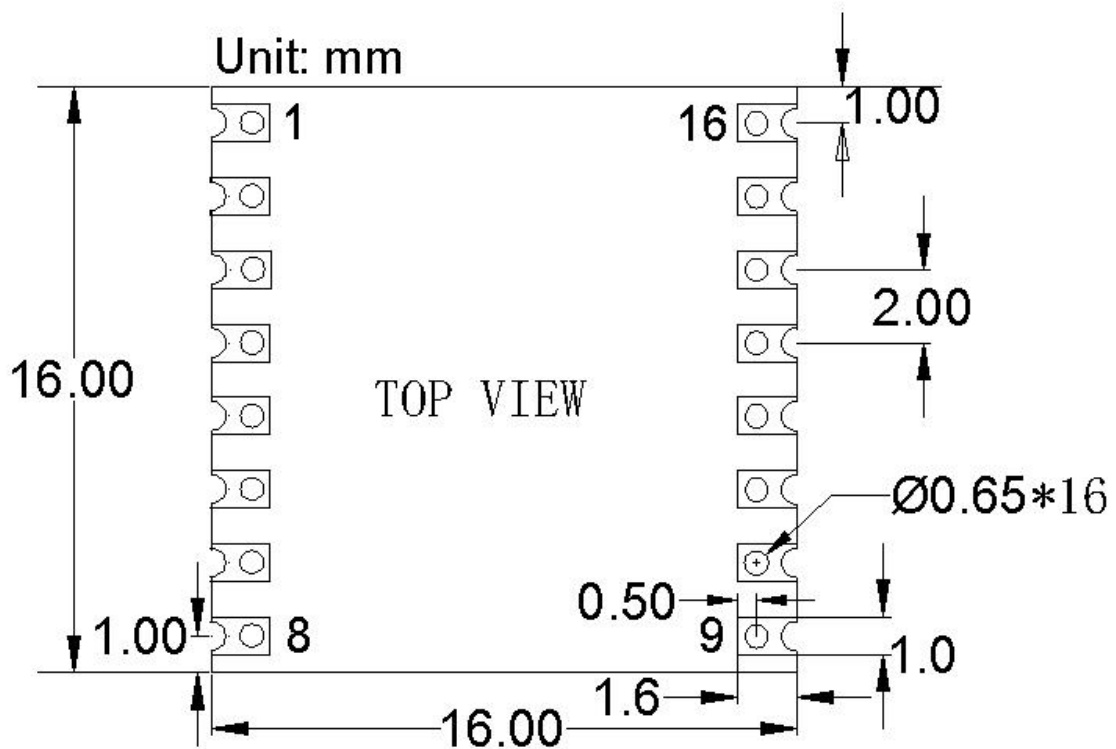
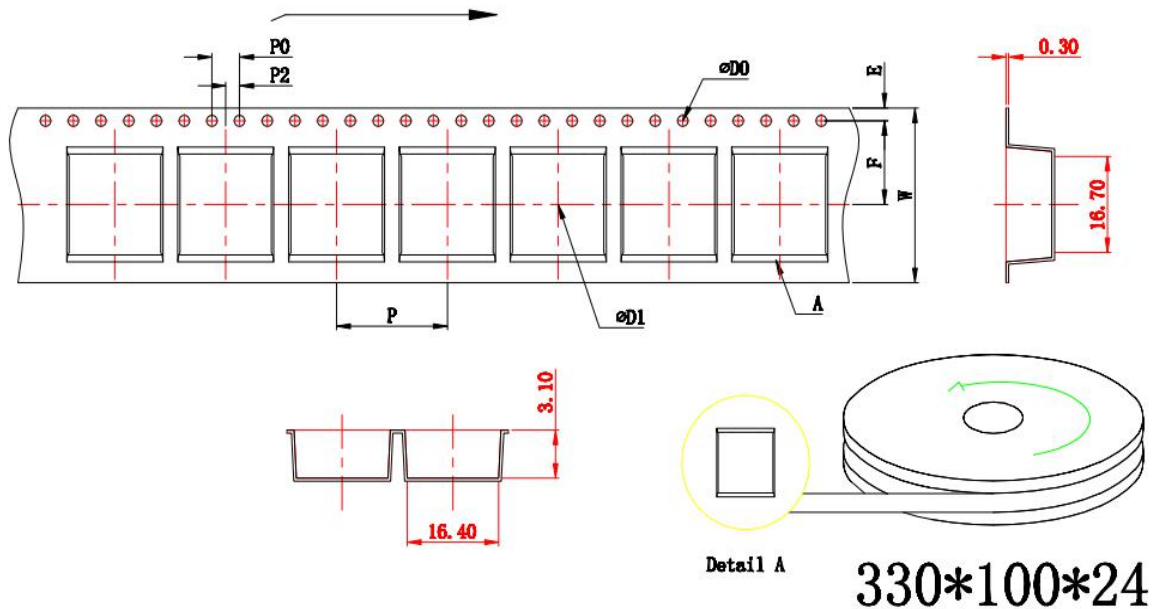

Figure 3-3 F8L10-N Outline Package

### 3.5 Tape and packaging instructions



Unit: mm

W	24.00±0.30	P0	4.00±0.10
S	---	A0	16.40±0.10
P	20.00±0.10	A1	
E	1.75±0.10	B0	16.70±0.10
F	11.50±0.10	B1	
P2	2.00±0.10	K0	3.10±0.10
D0	1.50+0.10/-0.00	K1	
D1	1.50+0.10/-0.00	t	0.30±0.05

### 3.6 Re-flow Temperature Specification

Please reference the IPC/JEDEC J-STD-020B for the Re-flow.

#### Soldering temperature

Using thermostat soldering iron do not exceed 340°C, and do not more than 2S every pin

#### Re-flow temperature

Recommend using the temperature profile below for re-flow

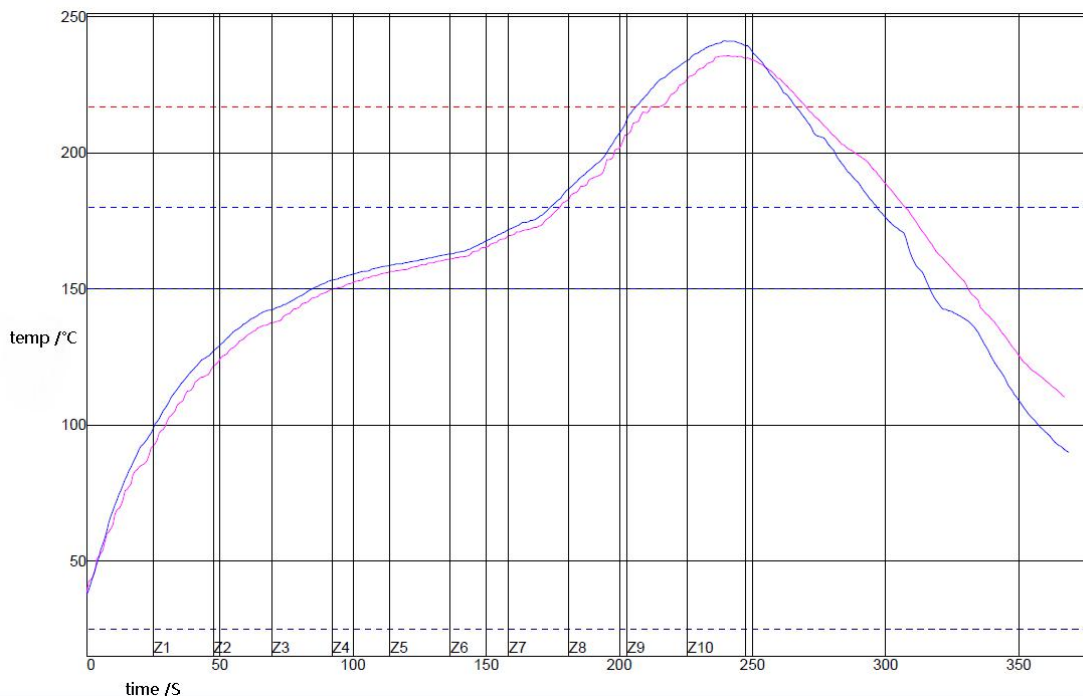

PWI=94%		Rising slop		Descending slop		pre-heat 25~150℃	
	2	1.96	-4%	-1.28	72%	93.1	23%
	3	2.05	5%	-1.43	57%	84.4	2%
D-Value		0.09		0.15		8.70	

PWI=94%		Constant 150~180℃		Re-flow 217℃		Maximum temperature		Descending slop 250~200℃	
	2	85.4	-15%	55.5	-27%	235.8	-54%	-1.15	94%
	3	89.4	-2%	60.5	-14%	241.3	-10%	-1.48	81%
D-Value		4		4.5		5.5		0.33	

## Chapter 4 Ordering Information

You can contact the sales of Xiamen Four-Faith Communication Technology Co., Ltd to buy the modules or EVB. Please specify the model you need.

Contact Four-Faith:



[Xiamen Four-Faith Communication Technology Co., Ltd.](#)

Add: Floor 11, Area A06, No 370, chengyi street, Jimei, Xiamen

Tel: +86 592-5907276 Fax:+86 592-5912735

Web:en.four-faith.com